

Doylestown Township Bike/Hike Committee
Meeting Notes
January 21, 2025 8:00 am
Doylestown Township Municipal Building

Present: Lynn Goldman, Tom Kelso, Judy Hendrixson; Larry Gage; Roger Clark; Louise Silberg; Caitlyn Hernandez, Doylestown Borough; Nicole McElroy; Emily Valmore; Christian Regosch, Bucks County; Chris Stanford, Michael Baker Engineers; Dylan Melsky, Baker Engineers; Board of Supervisors Liaison Judy Dixon, and Stephanie J. Mason, Township Manager.

Guests: Henry Friedberger, Pebble Hill Rd; Patricia Lukens, Cherry Lane and Mike Bowe, Bike Works.

Welcome

Ms. Goldman welcomed everyone to the meeting.

Minutes Approval – December 17, 2024 – On motion of Ms. Hendrixson, seconded by Mr. Gage the minutes were unanimously approved.

Easton Road Trail Township to Borough - Update

Mr. Stanford indicated that he is working on preliminary design, the PennDOT environmental issues for the project are being addressed. Unfortunately, the Callan Tract that installed a trail did not relocate the PECO pole, the Township engineer is working with the developer to get this relocated, as of now it is sitting in the middle of the trail. PennDOT/DVRPC is hosting a meeting to go over the project information and he reminded everyone there is a long way to go.

Pebble Hill Trail – Update

Ms. Mason indicated that Ms. Goldman, Mr. Kelso, Mr. Stanford and herself met with the owner of 485 Pebble Hill Road (Susan Romanus) on January 3rd. Mr. Friedberger was also in attendance. Ms. Romanus was very supportive of the trail concept. The key take aways are that the property owner at 485 Pebble Hill is very concerned about privacy, landscaping, fencing but still wants to be able to see the Stone Arch Bridge from their property. She did say that people trespass today on to their property, creating barriers that would prevent that from happening would be appreciated. Mr. Stanford also indicated that DVRPC has provided under their program a \$15,000 grant for Baker to do work on the concepts of the project.

Mr. Friedberger indicated that he and his neighbor, Susan, are supportive, but Susan is a naturalist and is concerned about privacy, although he's not an engineer or artist he did put together a sketch of a concept of a Corten Steel Spill Rail bridge that could be used. It would have steel in a patina finish with tempered glass that would allow for he and his neighbors to see through the glass to see the Stone Arch Bridge but yet protect people from trespassing. He also provided some examples, which are attached to the minutes. (Exhibit A) The Committee appreciated his information and said that they would look into his suggestion.

Mr. Gage asked further about the DVRPC grant to Baker. Mr. Stanford indicated that there are three or four tasks to look at right-of-way, doing research, creating estimates and concepts in detail, mostly the bridge and that area.

Mr. Friedberger indicated that the Township needs paths vs. ambulances. He sees so many folks running and biking on a very narrow road that's 35 mph, he is always concerned about someone getting hurt. He believes it will be a great enhancement for the community and hopes his fencing idea would prevent folks from entering the pond area, easy for maintenance and retain the viewshed of the bridge.

New Britain Road Trail Project – Update

Ms. Mason indicated that she, Mr. Tomko and Mr. Stanford met with members from the Morgan Hill HOA on January 6th. Reviewed the sidewalk and the widening and temporary construction easement especially in front of the landscaping bed. The HOA members agreed that they would like to retain the sidewalk which would include maintenance as they do now. They are fine with the trail and temporary easement. Paperwork will need to be prepared by the Township Solicitor.

Safe Cycling for School Children – Update

Ms. McElroy updated everyone that she is working with the principal and PE teacher at Linden and Carly from Bucks TMA. They are going to do some education in February. They are also working with the librarian at Kutz. Ms. McElroy runs the Book Fair at Kutz and finding books on cycling to gift to the library should be easy. She will have Carly speak with Christine at Kutz about the Bike to School Program this spring as well as the principal at Doyle.

She also indicated that Carly would like to expand the TMA program beyond the Central Bucks School District because of the grant she has for TMA.

Ms. Goldman indicated that she hopes that we do not need to rely on Carly and TMA in the future but that the Bike/Hike Committee can create a program through the schools that will continue on their own educating elementary school students on how to bike safely and be comfortable on trails, roads etc.

Mr. Kelso commented that he looked up children's books on cycling and found hundreds. He believes books that encourage bicycling, touring and maintenance are all helpful.

Ms. Valmore inquired about whether we could get Carly from TMA to make a presentation to Central Bucks School District and or their curriculum committee to adopt a Safe Cycling Program for elementary students.

Ms. McElroy suggested setting a meeting with the principal of Kutz, the PE teacher and librarian, see what the best way to go about incorporating safe cycling into a curriculum program. Once she has that information she can share it with the committee.

Ms. Goldman thought this was a good step but again, hopes something can be set up for all schools in the district. She understands that it will take time to develop that relationship.

Ms. Valmore indicated that going to a curriculum meeting may be appropriate.

Ms. McElroy asked for time for her to meet with the folks at Kutz then get a game plan together.

Update County Trail Projects

Mr. Regosch indicated that he's working on a poster size map of the existing trails in the Central Bucks area. He wants to work with Ms. Mason, Mr. Stanford and Mr. Kelso to finalize things. Mr. Gage asked if he could participate. Mr. Regosch will send out drafts of the map sometime next week.

County RFP Updates for the Upper Bucks Rail-Trail is being prepared.

Phase I of the Neshaminy Greenway is moving along.

Pump Track

Ms. Hernandez indicated that Doylestown Borough budgeted money, about \$30,000 to pave the Pump Track, is on their list for this year. She also indicated that Councilwoman Wyckoff is looking for sponsorship. The Borough put their Bike/Hike Committee back together.

Prioritize List of Future Projects:

Proposed Trail at Pine Run

No updates

Spring Valley – Hunter to Pebble Hill

No updates

E-Bike Policy

Ms. Dixon asked about E-Bike Policies and if Mr. Kelso could move forward and set up a meeting with the Chief of Police to talk about E-Cycling in and around the community.

Mr. Bove was in attendance; he said that he was associated with Bike Works. He is an avid cyclist; he wanted to know the best way of addressing a concern in Buckingham Township at Fells and Burnt House Roads. If you're running or biking on your way to Hansel Park there is a hill, it's very difficult, there is no real side shoulder, lots of concerns, people and bikes from Cold Springs Creamery Road will cross without having a safe crossing.

Ms. Dixon indicated that she spoke with PennDOT maintenance, Buck County, they indicated that 413 would be paved spring / summer 2025 and that they could add additional paving to the shoulder on 413, give it a little extra safety area for the bicyclists.

Ms. Silberg, Buckingham Township, indicated she would share this concern with Dana Cozza, Township Manager. She also indicated that Mr. Bole could set up a meeting with her, explain the situation and perhaps Buckingham Township could advocate additional safety improvements for cyclists and runners in the area of Burnt House Hill Rd and Fells.

Ms. Dixon indicated that if you are a runner, which she is, on Burnt House Hill near Fells it is very difficult.

It was also indicated that in 2011 there was an accident with a bicyclist in that area. It was mentioned that 200 - 300 cyclists a day are on the 413 / Burnt House Hill area.

Mr. Clark indicated that the Cherry Lane at the Brooks Tract portion of the trail has been done, he asked about maintenance. Until things are dedicated it is the responsibility of the developer.

Adjournment – Being no further the meeting adjourned at 8:50am.

Respectfully submitted by:

Stephanie J. Mason
Township Manager

Exhibit A

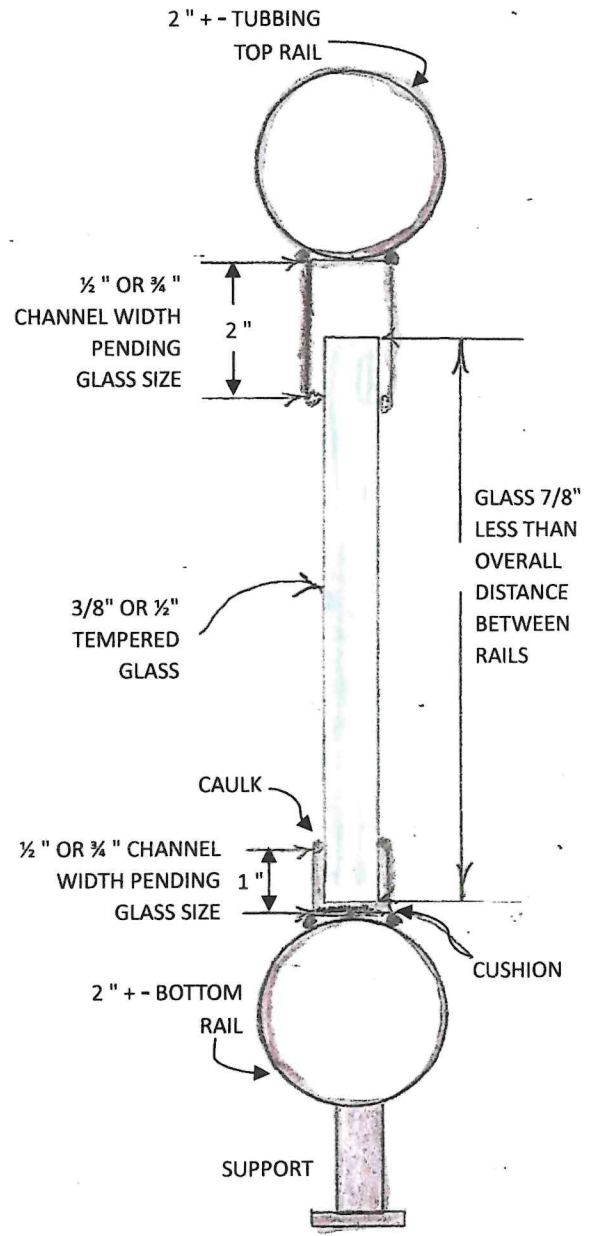
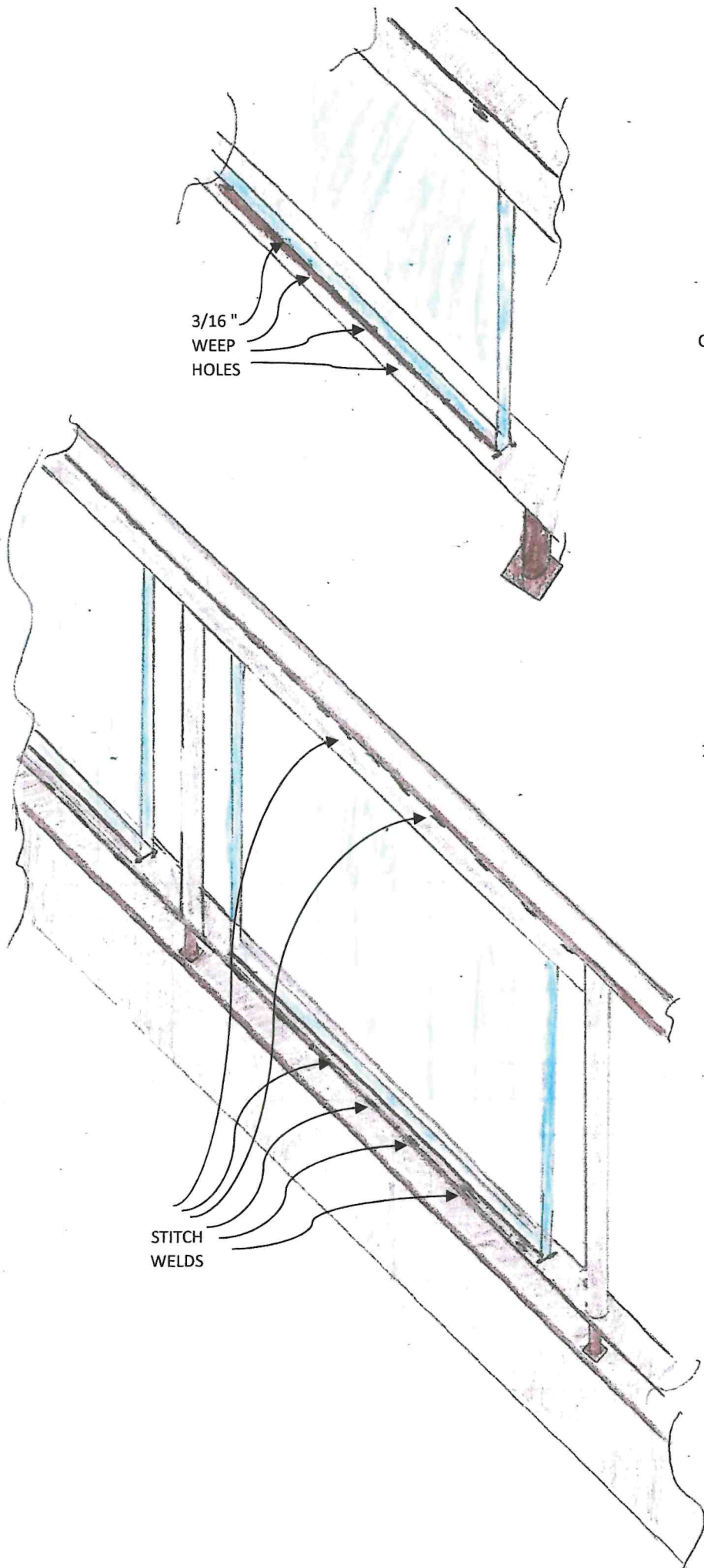

CORTEN STEEL SPILL WAY BRIDGE
RAIL CONCEPT

NO SCALE

TODD'S POND BRIDGE
CONCEPT DRAWING

HENRY FRIEDBERGER



07.20.2010 17:29

